

SMT CURRENT SENSE TRANSFORMERS

PE-68XXX Series



- Height:** 7.1mm Max
- Footprint:** 14.6mm x 12.6mm Max
- Current Rating:** up to 15A
- Frequency Range:** 50kHz to 500kHz

Electrical Specifications @ 25°C — Operating Temperature -40°C to +130°C

Part ^{5,6} Number	Turns Ratio	Current ² Rating (A)	Secondary Inductance (mH MIN)	DCR (mΩ MAX)		Hipot (V _{RMS})
				Primary (1,3-2,4)	Secondary (5-6)	
PE-68210	1:1:50	15	3.8	1.15	380	500
PE-68280	1:1:100	15	14.8	1.15	930	500
PE-68383	1:1:200	15	59.2	1.15	3900	500

NOTES:

- The temperature of the component (ambient temperature plus temperature rise) must be within the specified operating temperature range.
- The maximum current rating is based upon temperature rise of the component and represents the dc current which will cause a typical temperature rise of 40°C with no air flow when both one turn windings connected in parallel.
- To calculate the value of the terminating resistor (R_t) use the following formula: $R_t (\Omega) = V_{REF} * N / (I_{peak_primary})$
- The peak flux density of the device must remain below 2000 Gauss. To calculate the peak flux density for a uni-polar current use the following formula:

$$B_{PK} = 14.29 * V_{REF} * (Duty_Cycle_Max) * 10^5 / (N * Freq_kHz)$$
 * for bi-polar current applications divide B_{PK} as calculated above by 2.
- Optional Tape & Reel packaging can be ordered by adding a "T" suffix to the part number (i.e. PE-68210 becomes PE-68210T). Pulse complies to industry standard tape and reel specification EIA481.
- RoHS compliant parts are being introduced. Please contact Pulse for RoHS compliant part availability. If available, order part by adding "NL" to the part number (i.e. PE-68210 becomes PE-68210NL and PE-68210T becomes PE-68210NLT).

Mechanical

Schematic

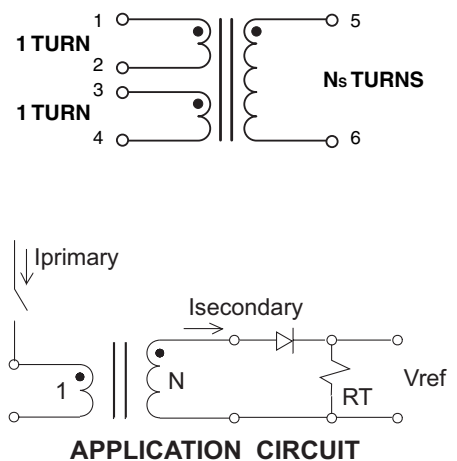
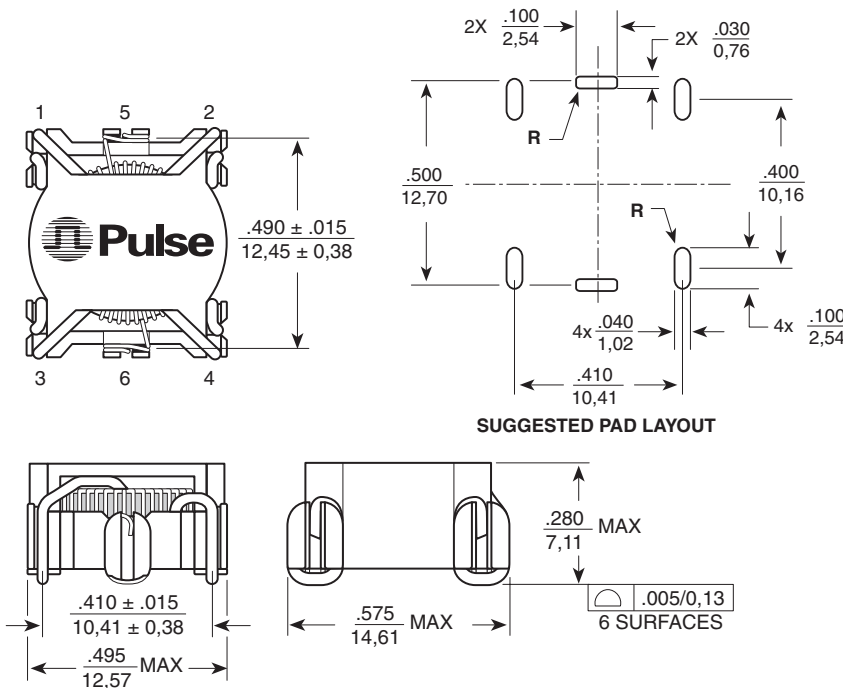

Dimensions: $\frac{\text{Inches}}{\text{mm}}$
 Unless otherwise specified, all tolerances are $\pm \frac{.010}{0.25}$