



Lithium-ion Battery

DATA SHEET

Battery Model: [LIR1632](#)

Prepared	Authorized	Approved
Zhe Hao, Wei	Feng , Li	Ji de, Wong

Manufacturer: EEMB Co., Ltd.

Website: <http://eemb.com>

This Specification describes the requirements of the lithium ion rechargeable battery supplied by EEMB Co., Ltd.

1.0 BASIC CHARACTERISTICS

1.1	Battery Type	LIR1632
1.2	Nominal Capacity	25 ± 5 mAh
1.3	Charging Voltage	4.2V
1.4	Nominal Voltage	3.6V
1.5	Standard Charge	Method: CC/CV (constant current / constant voltage) Current: 0.5C Voltage: 4.2V End Current: 0.05C
1.6	Maximum Charge Current	1C
1.7	Maximum Discharge Current	2C
1.8	Weight	Approx. 1.7 ± 0.3g
1.9	Operating Temperature	Charge: -20 °C ~ 45 °C Discharge: -20 °C ~ 60 °C
1.10	Storage Temperature	1 month: -20 °C ~ 60 °C 3 month: -20 °C ~ 45 °C 12 month: -20 °C ~ 25 °C
1.11	Appearance	There shall be no such defect as scratch, flaw, crack, rust, leakage, which may adversely affect commercial value of the cell.

Note: 1C = 1 Capacity

2.0 TECHNICAL REQUIREMENTS

2.1 Testing Conditions (unless otherwise specified)

Temperature: 20 ± 1 °C

Relative Humidity: 75 ± 5%RH

Accuracy of voltmeters and ammeters used in the test is equal to or better than the grade 0.5

2.2 Electrical Characteristics

NO	ITEM	TESTING INSTRUCTION	REQUIREMENTS
2.2.1	Charge Condition	Charge the battery with constant current 0.5C to 4.2V, and then charge at constant voltage 4.2V until the current decays to 0.05C during the constant voltage stage.	

Note: Any representations in this brochure concerning performance, are for informational purposes only and are not construed as warranties either expressed or implied, of future performance.

<http://eemb.com> global@eemb.com

2.2.2	Nominal Capacity	Within one hour after the charge according to 2.2.1, discharge at 0.2C until 2.75V cut-off voltage.	Capacity \geq nominal capacity
2.2.3	1C discharge	With in 1 hours after the charge according to 2.2.1, discharge at constant current 1C until 2.75V cut-off voltage. If the discharge duration does not reach specified value, the test may be repeated up to three times in total.	\geq 90% of the nominal capacity
2.2.4	Cycle Life	After the charge according to 2.2.1, the battery stays for 1 hour. At $25\pm 5^{\circ}\text{C}$, discharge the battery at constant current 0.5C until 2.75V cut-off voltage. Then the battery stays for 1 hour. A cycle defined as one charge and discharge. This charge and discharge circle shall be repeated 500 times.	The capacity at 500th cycle \geq 80% of the nominal capacity
2.2.5	Electricity Preservation	After the charge according to 2.2.1, the battery stays at $20\pm 5^{\circ}\text{C}$ for 28 days and then discharge at 0.2C to 2.75V cut-off.	The discharge capacity 80% of the nominal capacity
2.2.6	High Temperature Performance	After the charge according to 2.2.1, store the testing cells at $60\pm 2^{\circ}\text{C}$ for 4 hours. Then discharge at 1C until 2.75V cut-off voltage.	The discharge capacity 90% of the nominal capacity
	Low Temperature Performance	After the charge according to 2.2.1, store the testing cells at $-20\pm 2^{\circ}\text{C}$ for 16~24 hours. Then discharge at 0.2C until 2.75V cut-off voltage	The discharge capacity 60% of the nominal capacity
2.2.7	Short-circuit	After the charge at 2.2.1, short circuit the cathode and anode. Stop testing when battery temperature decays to about 10°C from the maximum temperature.	No fire, no explosion
2.2.8	Overcharge	Put the testing batteries connecting with thermocouple in ventilated cabinet, connect the cathode and anode to a power supply with CC/CV (constant current / constant voltage) function. Adjust the current to 3C and voltage to 4.6V. Then charge the battery at 3C until the limit voltage reaches 4.6V. The charging continued for 8 hours.	No fire, no explosion

Note: Any representations in this brochure concerning performance, are for informational purposes only and are not construed as warranties either expressed or implied, of future performance.

2.2.9	Hot box test	Put the testing batteries connecting with thermocouple in constant temperature box. Heat the batteries and box (speed of ascending temperature is $5\pm 2^{\circ}\text{C}$ at room temperature simultaneously). Monitor the temperature change of the box. Keep for 10 minutes after the box temperature reaches $150\pm 2^{\circ}\text{C}$, then stop the test.	No fire, no explosion
2.2.10	Vibration test	After the charge at 2.2.2, put the testing battery on the vibration testing equipment. Vibrate it from X,Y two different directions for 30 minutes (Frequency of vibration: 10Hz-30Hz, displacement of single swing: 0.38mm; Frequency of vibration: 30Hz-55Hz, displacement of single swing: 0.19mm) in swept vibration from 10Hz to 50Hz. The swept rate is 1 oct/min.	No fire, no explosion $\geq 90\%$ of the nominal capacity
2.2.11	Drop test	After the charge at 2.2.2, free drop the testing battery from the height of 1.0 meter (the lowest point height) once from the each six positive and negative X,Y,Z directions to the hardwood board (the thickness of the board is about 50mm).	No fire, no explosion $\geq 90\%$ of the nominal capacity

3.0 BATTERY DIMENSION

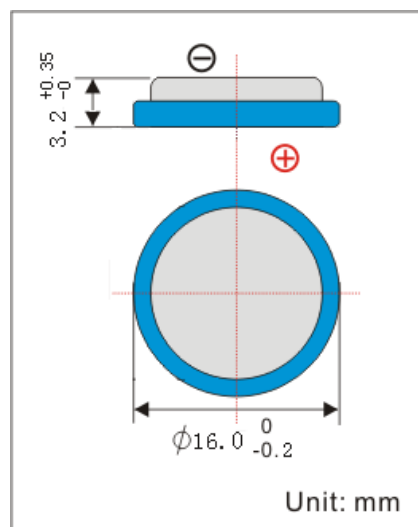

Note: Any representations in this brochure concerning performance, are for informational purposes only and are not construed as warranties either expressed or implied, of future performance.

4.0 ELECTRONIC CHARACTERISTICS CURVE

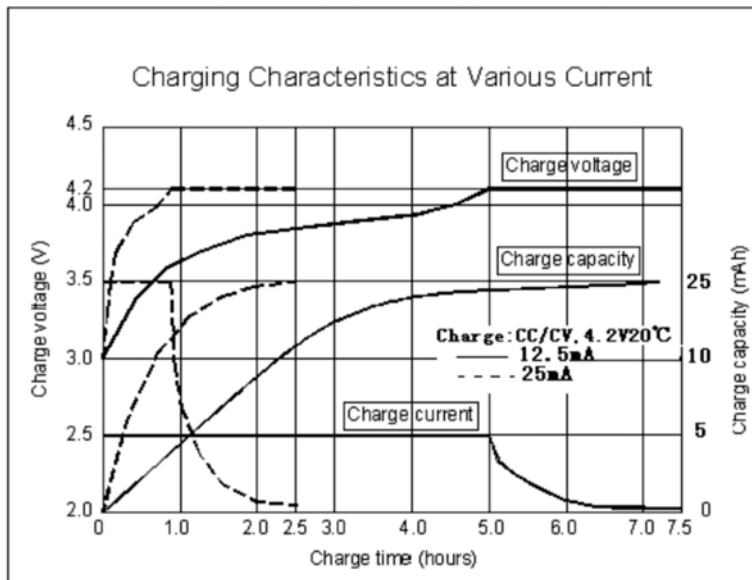
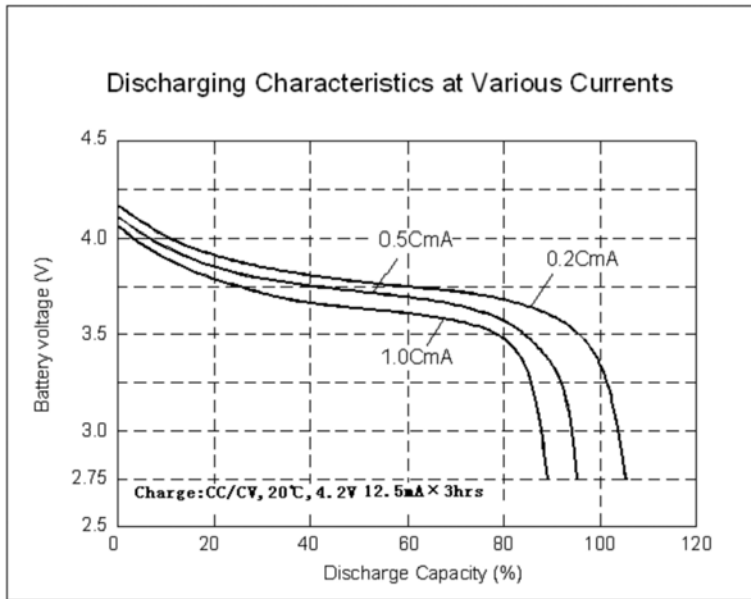

Note: Any representations in this brochure concerning performance, are for informational purposes only and are not construed as warranties either expressed or implied, of future performance.

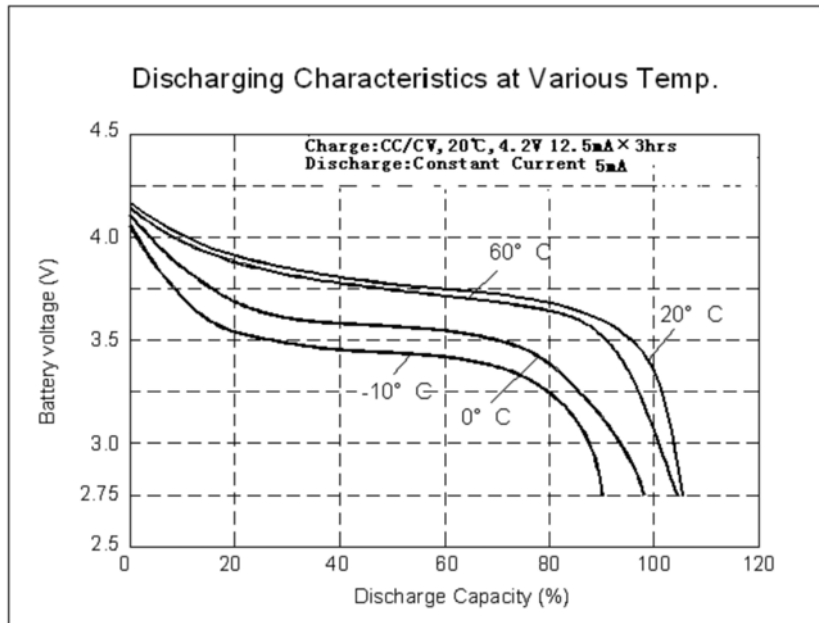

Storage Characteristics

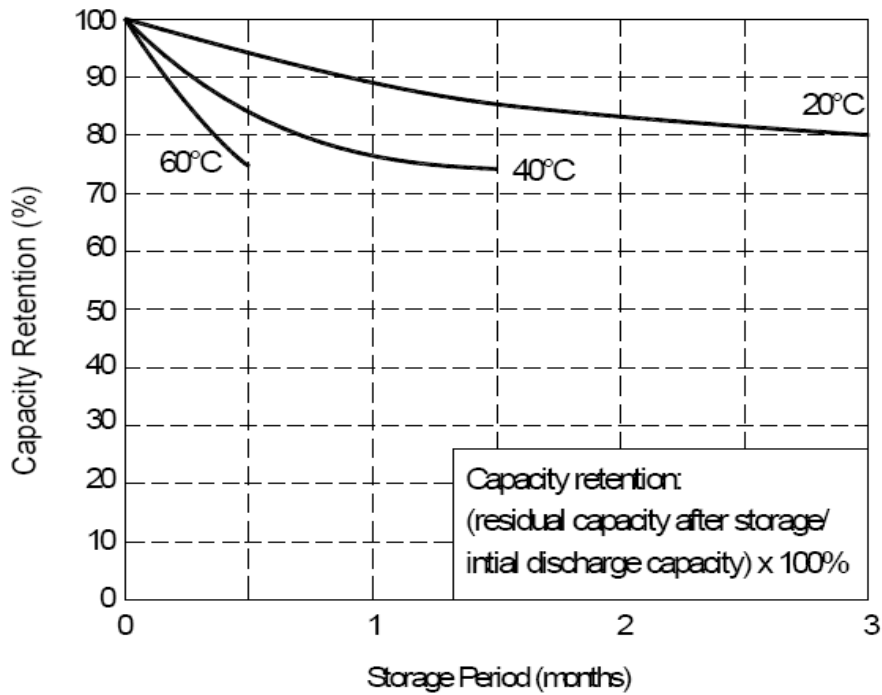

Note: Any representations in this brochure concerning performance, are for informational purposes only and are not construed as warranties either expressed or implied, of future performance.
<http://eemb.com> global@eemb.com

Cycle Life

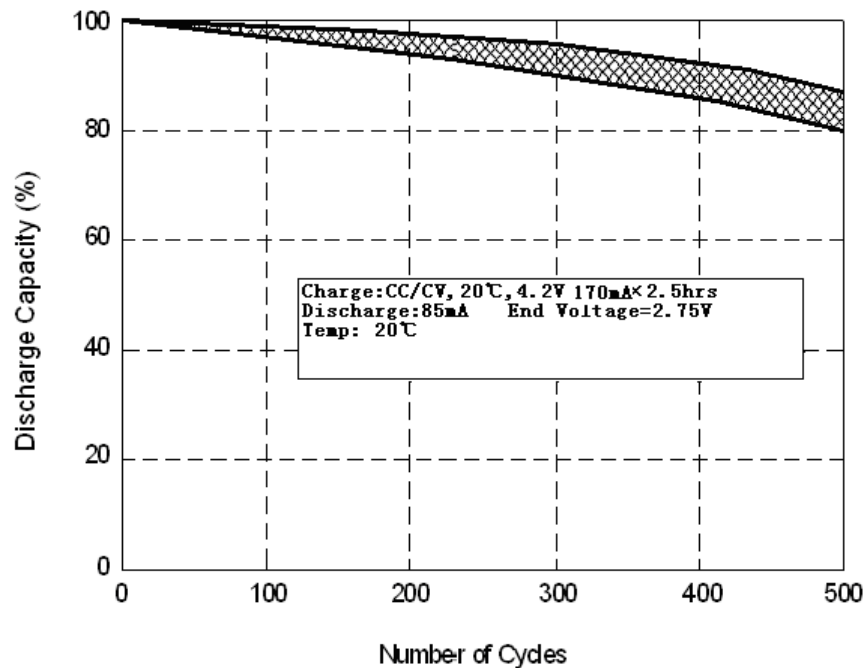

5.0 WARNINGS AND CAUTIONS IN HANDLING THE Lithium-ion BATTERY

To prevent a possibility of the battery from leaking, heating or explosion, please observe the following precautions:

WARNINGS!

- 1) Do not immerse the battery in water or seawater, and keep the battery in a cool dry surrounding if it stands by.
- 2) Do not use or leave the battery near a heat source as fire or heater
- 3) When recharging, use the battery charger specifically for that purpose
- 4) Do not reverse the position (+) and negative (-) terminals
- 5) Do not connect the battery to an electrical outlet
- 6) Do not discard the battery in fire or heat it
- 7) Do not short-circuit the battery by directly connecting the positive (+) and negative (-) terminal with metal objects such as wire.
- 8) Do not transport or store the battery together with metal objects such as necklaces, hairpins etc.
- 9) Do not strike or throw the battery
- 10) Do not directly solder the battery and pierce the battery with a nail or other sharp object.

Note: Any representations in this brochure concerning performance, are for informational purposes only and are not construed as warranties either expressed or implied, of future performance.

CAUTIONS!

- 1) Do not use or leave the battery at very high temperature (for example, at strong direct sunlight or in a vehicle in extremely hot weather). Otherwise, it can overheat or fire or its performance will be degenerate and its service life will be decreased.
- 2) Do not use it in a location where static electricity is great, otherwise, the safety devices may be damaged, causing hidden trouble of safety.
- 3) If the battery leaks, and the electrolyte get into the eyes. Do not rub eyes, instead, rinse the eyes with clean running water, and immediately seek medical attention. Otherwise, it may injure eyes or cause a loss of sight.
- 4) If the battery gives off an odor, generates heat, becomes discolored or deformed, or in any way appear abnormal during use, recharging or storage, immediately remove it from the device or battery charger and stop using it.
- 5) In case the battery terminals are dirt, clean the terminals with a dry cloth before use. Otherwise power failure or charge failure may occur due to the poor connection with the instrument.
- 6) Be aware discarded batteries may cause fire, tape the battery terminals to insulate them.

Note: Any representations in this brochure concerning performance, are for informational purposes only and are not construed as warranties either expressed or implied, of future performance.

<http://eemb.com> global@eemb.com