



Solutions Start Here



Release 1.0

Contents

1.1	General information	2
1.2	Contact for support	2
1.3	Important notice	3
1.4	Safety and hazards	3
1.5	Conventions used in this manual	3
1.6	Related documentation.....	4
1.7	Abbreviations.....	4
1.8	Revision history	4
2.1	Overview.....	5
2.2	Identification.....	6
2.3	Physical dimensions and weight.....	7
2.4	Product features and technical data	7
2.5	Telic certified accessories	9
3.1	Safety instructions	11
3.2	SIM card precautions.....	12
3.3	Antenna precautions	13
3.4	Storage conditions	13
4.1	Power connector	14
4.2	Antenna requirements	16
4.3	SIM card reader	16
4.4	RS232 serial Port	17
4.5	Mini USB connector	18
5.1	Switch ON the modem	18
5.2	Configuration of the bit rate on the serial interface	19
5.3	Power off the modem	20
5.4	Using low power mode of the modem	21
5.5	Operating states / green LED	21
5.6	Status LEDs (one yellow, one red).....	22
5.7	Current consumption measurements	22
5.8	Additional configuration	23
6.1	Where to install the modem.....	23
6.2	How to install the modem	24
6.3	Antenna	25

1 General terms and conditions

This technical description contains important information for the installation and use of the LT910-EUbis terminal. Read it carefully before working with the LT910-EUbis terminal.

We cannot be held responsible for material loss or personal injury that is due to noncompliance with the safety instructions. The warranty will be void in such circumstances.

Telic reserves the right to change the included information without prior notice and does not take responsibility for errors in the document and/or for any missing information.

1.1 General information

This installation manual consists of the following chapters:

Chapter	Description
1	General Information provides basic information such as the conventions for the warning levels, applicable related documentations, used abbreviations, a revision history and contact information.
2	Product Description provides a brief overview about the mechanical specification of the product as well as an overview of the functions and features of the device as well as the available accessories.
3	Safety and Product Care addresses the indented use of this device and safety related information important to read before using the device.
4	Electrical Description describes the electrical characteristics and pin allocation of the device.
5	Operation provides details relating to the commissioning of the device, including details on activating special features such as low power modes.
6	Installation of the modem provides instructions about how to install the device for the M2M application.

1.2 Contact for support

Please submit your request to TELIC AG customer support:

support@telic.de

Information about Telic AG products and accessories are available from the following web site:

<http://www.telic.de>.

1.3 Important notice

Due to the nature of wireless communications, transmission and reception of data can never be guaranteed. Data may be delayed, corrupted (i.e., have errors) or be totally lost. Although significant delays or losses of data are rare when wireless devices such as the LT910-EUbis terminal are used in a normal manner with a well-constructed network, the LT910-EUbis should not be used in situations where failure to transmit or receive data could result in damage of any kind to the user or any other party, including but not limited to personal injury, death, or loss of property. Telic AG accepts no responsibility for damages of any kind resulting from delays or errors in data transmitted or received using the Telic AG product, or for failure of the Telic AG product to transmit or receive such data.

1.4 Safety and hazards

Do not operate the Telic AG product in areas where blasting is in progress, near Hazards medical equipment, near life support equipment, or any equipment which may be susceptible to any form of radio interference. In such areas, the Telic AG product **MUST BE POWERED OFF**. The Telic AG product can transmit signals that could interfere with this equipment.

1.5 Conventions used in this manual

The following conventions for warning levels are used in this manual:

Warning



Warnings against hazards that may result directly in **serious injuries or death** in case of nonobservance.

Caution



Warnings against hazards that may result in **injuries** in case of nonobservance.

NOTICE

Warnings against hazards that may result in **material damage** in case of nonobservance.



Indicates that the device can be damaged by electrostatic discharge.

	This note contains helpful suggestions or references to material not covered in the document.
---	---

1.6 Related documentation

Please consult the download zone of the Telic AG website for additional documentation related to the build-in module LE910R1-EU, such as AT command reference. Note that these documents can be accessed online only after you have registered on our website and agreed with our terms of use. Please follow this link to register or create a user account:

<https://www.telic.de/en/our-products/downloads>

1.7 Abbreviations

Abbreviation	Explanations
WWAN	Wireless Wide Area Network
CSD	Circuit Switched Data
DCE	Data Circuit Terminating Equipment
DTE	Data Terminal Equipment
GPRS	General Packet Radio Service
GSM	Global System for Mobile Communication
ME	Mobile Equipment
MO	Mobile Originated
MS	Mobile Station
RF	Radio Frequency
SIM	Subscriber Identity Module
SMS	Short Message Service
TA	Terminal Adapter
TE	Terminal Equipment
TS	Telecom Services
VIL	Voltage Input Low
VIH	Voltage Input High

Table 1: Abbreviations

1.8 Revision history

Revision	Date	Changes
1.0	12.07.2024	Initial version

Table 2: Documentation change log

2 Product description

2.1 Overview

The pictures below show the mechanical design of the LT910-EUbis terminal along with the positions of the different connectors and mounting holes. The LT910-EUbis terminal case is made of durable PC/ABS plastic

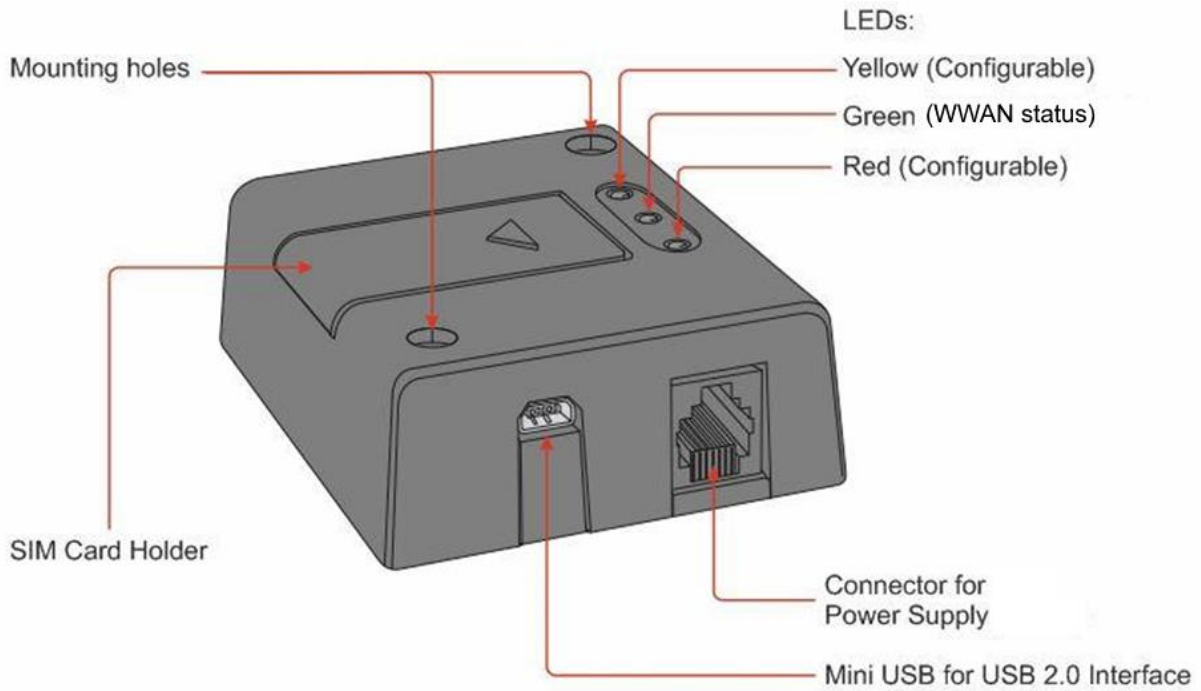

Figure 1: Connectors on rear side

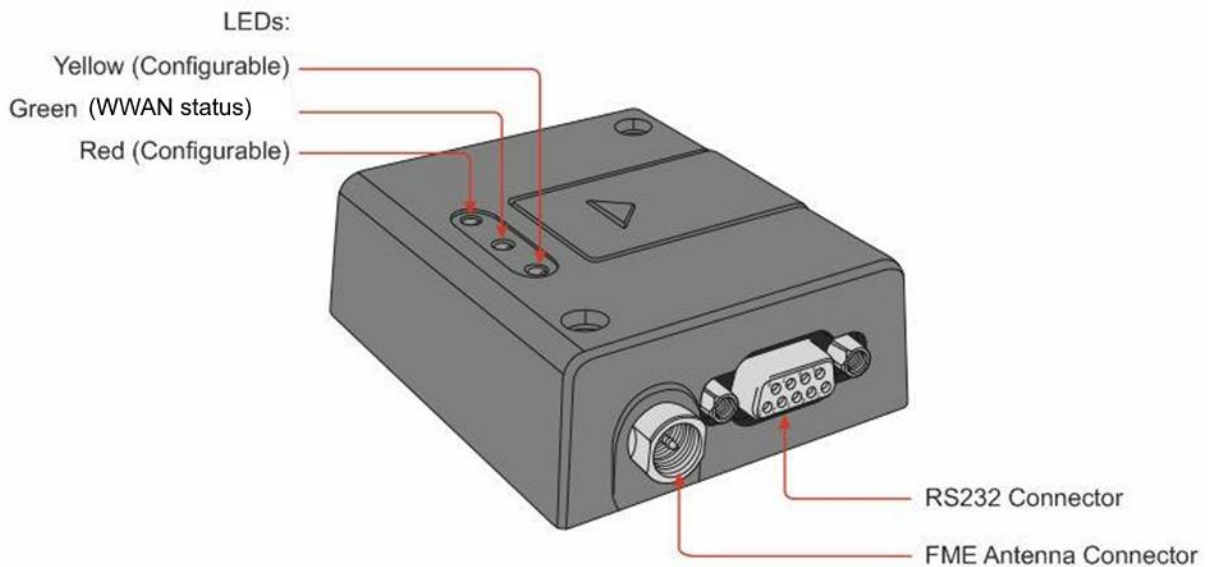

Figure 2: Connectors on front side

PLEASE NOTE THE FOLLOWING:

- The terminal can be securely fitted into your application by using the mounting holes positioned at the two corners of the device.
- The SIM card can be inserted without the need for additional tools.
- Section “4 Electrical Description” describes the pins and electrical characteristics of the terminal’s various connectors.
- Section “4.2 Antenna Connector” provides information about the antenna connector.



Special DIN Rail Mounting Brackets (Art-nr. 12304) is available as an accessory item which allows installation of the modem in industrial environments using DIN Rails. For more details of our accessories please check chapter 2.5 Telic Certified Accessories.

2.2 Identification

On the bottom of the device, you will find the type label.

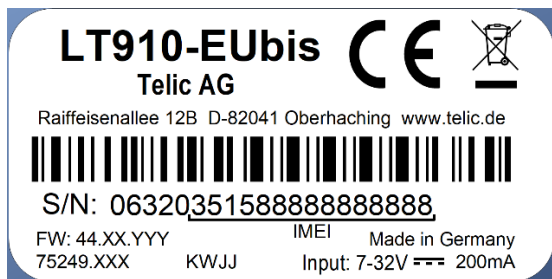

Label	Description
S/N	Serial number ¹
	Serial number barcode
IMEI	International Mobile Equipment Identity
FW	Firmware version
CE	CE mark
	Disposal in accordance with European directive 2002/96/CE

¹ Note that the serial number consists of a 5-digit product ID followed by the device’s IMEI.

2.3 Physical dimensions and weight

Overall dimensions: 77 x 66 x 26 mm

Weight: 90 g

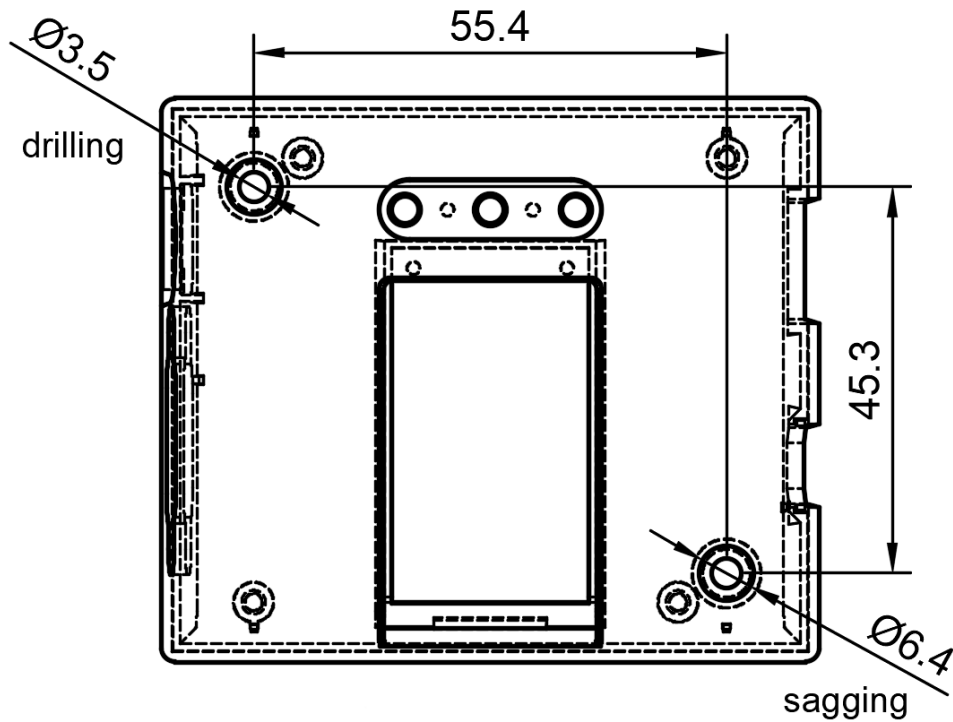

Figure 3: Illustration of the exterior casing

2.4 Product features and technical data

NOTICE

Telic AG may, at any time and without notice, make changes or improvements to the products and services offered and / or cease producing or commercializing them.

NOTICE - Optional Features

Features identified as "optional" in this document are not assembled by default. Please contact our sales team at info@telic.de to clarify the details for ordering terminal variants.

Category	Features	Details
Air Interface	LTE frequency bands	B1, B3, B7, B8, B20, B28
	UMTS frequency bands	Not Available
	GSM frequency bands	B3, B8
	LTE FDD Cat.1	LTE FDD Cat 1 bis 3GPP Release 13 compliant
	Output Power	0.2 W, 23 dBm @ LTE 1 W, 30 dBm @ GSM 1800 2 W, 33 dBm @ GSM 900
	SMS	SMS over IMS
	SIM Card Holder	1x (1.8/3 Volt)
	LEDs	1x WWAN + 2 configurable
	Type Approvals	CE, WEEE, RoHS and REACH
Connectors / interfaces	D-Sub (9-pin)	1x Female (RS232)
	USB	1x Mini-USB
	RJ11	For details have a look at section "Power Connector"
	Antenna	1x (FME male)
Software	AT Command Set	TS 27.005, 27.007 and Telit custom AT commands
	Programming Language	Not Available
	SIM Application Toolkit	SIM application tool kit 3GPP TS 51.01
	TCP/IP Stack	UDP, TCP, PPP, HTTP, HTTPS, NTP, FTP stack
	SW Update	FOTA
Power Management	Voltage Range	7V - 32V
Hardware Characteristics	Operating Temperature	-30°C to +75°C  It is not recommended to operate the terminal permanently on full load at maximum temperature. To monitor the temperature please use the AT command AT#TEMPMON
	Dimensions	77 x 66 x 26 mm
	Weight	90 g

Table 3: Feature overview

2.5 Telic certified accessories

NOTICE

The antennas listed in this section are suitable for use with LTE networks.
Please check, though, which frequency bands your mobile network service provider supports.

Product	Picture	Description	Part number
Magnetic antenna LTE		FME female connector 3m Frequencies: 698-960 MHz, 1710-2170 MHz, 2500-2700 MHz Dimensions: 31 x 72 mm	74672
Rectangular antenna LTE		FME female connector Frequencies: 824~894/1710~2690MHz Dimensions: 9 x 61 mm	74673
Stub antenna LTE		FME-female connector Frequencies: 824~894/1710~2690MHz Dimensions: 18 x 55,5 mm	74705
Roof antenna LTE		FME-female connector, 2,5m Frequencies: 689-960 MHz, 1710-2170 MHz, 2500-2700 MHz Dimensions: 80 x 74x 14,7 mm	12043

Product	Picture	Description	Part number
DIN Rail Mounting Bracket Rectangular		DIN Rail adapter (rectangular)	12304
Terminal Power Supply		Power supply 6pin Mini Western-Plug, Input 100- 240V AC Output 12V DC, 1,5A Length: 1500±50mm	12002
Terminal Power Cable		Power cable Length: 1500 ± 30	12003
RS232 Cable		RS232 cable, 9-pin Sub-D-connector, male/female Length: 2m	12004
Mini USB with open ends		USB cable for terminals: - for I/O Connection Length: 600±20mm	12301

Table 4: Accessories list

Please contact your distributor or Telic AG for availability or check Telic's webpage <http://www.telic.de>.

3 Safety and product care

This device has been designed in accordance with industrial standards, manufactured with high quality materials, and thoroughly tested. Nevertheless, its use may constitute a risk to persons or cause material damage.

The following safety instructions must be followed to ensure the safety of users and of the device.

NOTICE

If these instructions are ignored, Telic AG will not assume responsibility for any damages that are incurred. Telic AG may refuse warranty claims where evidence of product misuse is found.

Please read the information in this section and the information in Section 6 Installation of the modem before starting your integration work!

3.1 Safety instructions

PLEASE READ THESE SAFETY INSTRUCTIONS AND KEEP A COPY OF THEM.

The LT910-EUbis terminal contains highly integrated components which can be damaged by electrostatic discharge.



Therefore, only touch the LT910-EUbis terminal on the housing or connectors and avoid touching the components on the board.

- Always ensure that the use of the modem is permitted. The modem may present a hazard if used in the proximity of personal medical electronic devices. As a rule, the modem must not be used in hospitals, airports or planes.
- Never use the modem at a gas station, refueling point, blasting area or in any other environment where explosives may be present.
- Operating the modem close to other electronic devices, such as antennas, television sets, and radios may cause electromagnetic interference.
- This product is intended to be used with the antenna or other radiating element at least 20 cm away from any part of the human body. In applications where this rule cannot be applied, the application designer is responsible for providing the SAR measurement test report and declaration.
- You are responsible for observing your country's safety standards, and where applicable, the relevant wiring rules.

Warning



When using products which are exposed to electric voltage the valid regulations must be observed.

Always make sure that the device is disconnected from the power supply before opening it. You should only use tools on components, modules or devices if they are disconnected from the power supply and the electric charge, which may still be stored in some components inside the device, has been discharged. All cables and wires which are energized and connected to the device, the module or components must be checked regularly for any damage of the isolation shield or fractures of the cables. If the supply cables are visibly damaged the device must be taken out of commission immediately.

When using components or modules, the specification given in the corresponding description of these components must strictly be observed. The device shall be operated only by appropriately qualified personnel.

This device shall only be used for its intended purpose.

Please note that the quality and availability of the WWAN network is depending on the network coverage in the area of deployment and the performance of the network provider. We are not responsible for any wireless connection errors or data loss caused by these external factors.

General precautions

The LT910-EUbis terminal is designed for indoor use only. To use it in an outdoor application it must be integrated into a weatherproof enclosure. Do not exceed the environmental and electrical limits as specified in section "2.4 Product Features and Technical Data".

- Avoid exposing the modem to open flames or to extreme hot or cold temperatures.
- Never try to dismantle the modem yourself. There are no components inside the modem that can be serviced by the user. If you attempt to dismantle the modem, you will invalidate the warranty.
- The LT910-EUbis terminal must not be installed or located where the surface temperature of the plastics case may exceed 75°C.
- All cables connected to the LT910-EUbis terminal must be secured or clamped, immediately adjacent to the modem's connectors, to provide strain relief and to avoid transmitting excessive vibration to the modem in the installation.
- Ensure the cables, supplying power, and input cable to the LT910-EUbis terminal do not exceed 3 meters.
- To protect power supply cables and meet the fire safety requirements when the unit is powered from a battery or a high current supply, connect a fast 1.25 fuse in line with the positive supply.
- Do not connect any incompatible components or products to the LT910-EUbis terminal.

3.2 SIM card precautions

Before handling the SIM card in your application, ensure that you are not charged with static electricity. Use proper precautions to avoid electrostatic discharges.

When the SIM card hatch is opened, the SIM card connector lies exposed under the SIM card holder.



Caution! Do not touch these connectors! If you do, you may release an electrical discharge that could damage the modem or the SIM card.

When designing your application, the SIM card's accessibility should be considered. We always recommend that you have the SIM card protected by a PIN code. This will ensure that the SIM card cannot be used by an unauthorized person.

3.3 Antenna precautions

Consider the risk of lightning if the antenna is to be installed outside. Follow the instructions provided by the antenna manufacturer.

NOTICE

Please note that this LTE device is designed for use with one single antenna only. It does not support antenna diversity.

- Never connect more than one modem to a single antenna. The modem can be damaged by radio frequency energy from the transmitter of another modem.
- Like any mobile station, the antenna of the modem emits radio frequency energy. To avoid EMI (electromagnetic interference), you must determine whether the application itself, or equipment in the application's proximity, needs further protection against radio emission and the disturbances it might cause. Protection is secured either by shielding the surrounding electronics or by moving the antenna away from the electronics and the external signals cable.
- The modem and antenna may be damaged if it encounters ground potentials other than the one in your application.

3.4 Storage conditions

It is recommended to store the unit within a temperature range from +15°C to +35°C and a relative humidity of max. 60% without condensation.

4 Electrical description

The modem uses the following connectors:

- RJ11 6 way (power)
- Mini USB (data)
- SIM card reader
- FME male coaxial jack (antenna connector)
- Sub-D female socket, 9-pin (RS232 serial port)

4.1 Power connector

An RJ11 six-way connector, as shown and described below, serves as a means of supplying and controlling DC power to the modem. The use of an external power supply is necessary as the USB port is not intended to be used as power source.

The supply voltage VCC required by the modem is 7V - 32V DC. Please note that applying the supply voltage does not switch the modem on.

Please see chapter 5.1 Switch ON the modem for further important details about TO_IN and power supply requirements.



VCC and GND are reverse polarity and overvoltage protected if the antenna interface and the user's application are not used or connected to separate grounds. Excessive reverse voltage or overvoltage can destroy the device.

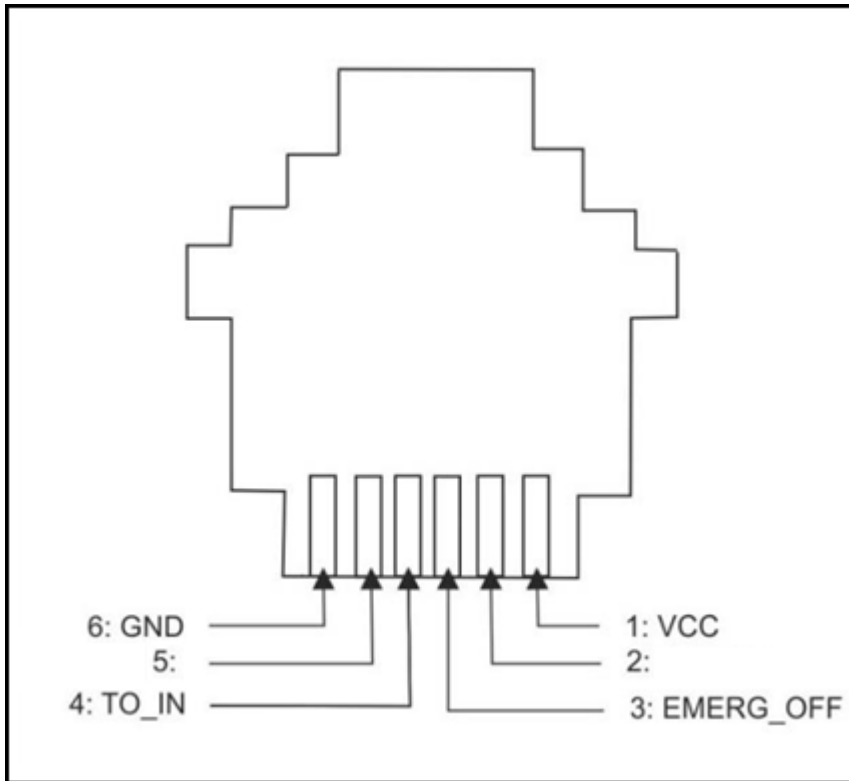

Figure 4: RJ11 pin connector

Pin	Signal	Direction	Limits	Description
1	VCC	Input	7 – 32V	Positive power input, DC
2	not used			
3	EMERG_OFF	Input	0 – 32V	Positive edge triggered signal to switch off modem. Only use after modem is fully switched on (PWRMON is HIGH). $V_{IH} > 5V$, $V_{IL} < 0.5V$ Power off: $t > 3s$ The maximum time to shut down the device is 25 seconds.
4	TO_IN	Input	7 – 32V	Positive edge triggered signal; used to switch on the modem. $V_{IL} < 0.5V$; $V_{IH} > 7V$ 1. Power on pulse: $t > 1s$ and $t < 5s$ with VCC applied. 2. Continuous power to VCC and TO_IN Provide continuous power to VCC. Provide continuous power TO_IN.
5	not used			
6	GND	Input		Negative power (ground) input and return path for TO_IN and EMERG_OFF

Table 5: RJ11 pin and signals description

4.2 Antenna requirements

Antenna Requirements

The antenna connection and board layout design are the most important aspect in the full product design as they strongly affect the general performance of the product, so read carefully and follow the requirements and the guidelines for a proper design.

The antenna and antenna transmission line on PCB for a Telit LE910R1 device shall fulfil the following requirements:

Item	Value
Frequency range	Depending by frequency band(s) provided by the network operator, the customer shall use the most suitable antenna for that/those band(s)
Bandwidth	See table 33: Bandwidth
Impedance	50 ohm
Input power	GSM: > 33dBm Average power LTE: > 24dBm Average power
VSWR absolute max	≤ 10:1 (limit to avoid permanent damage)
VSWR recommended	≤ 2:1 (limit to fulfill all regulatory requirements)

4.3 SIM card reader

The terminal is fitted with a SIM card reader designed for 1.8V and for 3V SIM cards. It is the hinge type which is lockable in the horizontal position and is accessed through a removable panel.

4.4 RS232 serial Port

Warning

To enable the WWAN module to send data over the serial interface:



- RTS must be connected and permanently active, i.e., between +3V and +15V (measured threshold 1.8V)
- RTS must be connected and can be dynamically activated via HW handshake (RTS/CTS)

The modem supports a standard RS232 serial interface via its 9 pin D-sub connector. In line with serial communication terminology, the terminal should be considered as the data circuit terminating equipment (DCE) and the external application or computer as the data terminating equipment (DTE).

The maximum data rate to communicate with the LT910-EUbis terminal is 921600 bits per second. The default data rate is 115200 bps.

Pin	Signal	Direction	Limits	Description
1	DCD	Output	> + 4V < - 4 V	Data carrier detect
2	RD	Output	> + 4V < - 4 V	Received data
3	TD	Input	> + 2,4V < 0.8 V	Transmitted data
4	DTR	Input	> + 4V < 0.8 V	Data terminal ready
5	GND	-	0 V	Ground connection
6	DSR	Output	> + 4V < - 4 V	Data set ready
7	RTS	Input	> + 2,4V < 0.8 V	Request to send
8	CTS	Output	> + 4V < - 4 V	Clear to send
9	RI	Output	> + 4V < - 4 V	Ring indicator

Table 6: Electrical characteristics of the serial port signals

4.5 Mini USB connector

Figure 5 gives an overview about the pin assignment of the mini-USB connector. The modem supports a standard USB 2.0 full speed slave interface to receive AT-commands as well as data transmissions.

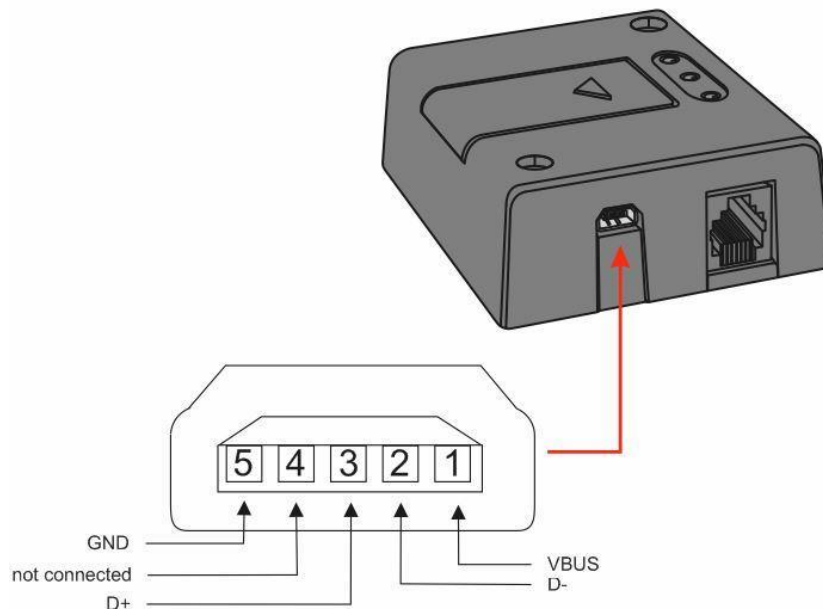

Figure 5: Mini USB type B connector

5 Operation

5.1 Switch ON the modem

NOTICE

To ensure correct operation of the terminal, please ensure that a SIM card has been inserted into the terminal prior to switching it on.

Do not insert a SIM card into the device while it is switched on. If you find that the device is switched on but missing a SIM card, first switch off the modem and insert the SIM card.

Note that the device does not have a SIM card detect feature.

To switch on the modem, you have two options:

1. Method 1: Continuous Power to VCC and TO_IN

Provide continuous power to VCC.

Provide continuous power TO_IN (pin 4).

- **Method 2: Power Pulse to TO_IN**

Provide continuous power to VCC.

Provide timed power to TO_IN.

Supply power to TO_IN for at least 1 second but no more than 5 seconds.

After the duration of 1 to 5 seconds, remove the power from TO_IN.

The terminal will power on after this timed power input and will remain operational even after power to TO_IN is removed.

The modem is fully operational after 20 seconds. Connection to a network may take longer depending on coverage and reception conditions and is outside the scope of the terminal.

Although this will not be an issue in almost all typical applications of the modem, there are a few cases in which the modem might not recognize the power up signal. This is no failure of the modem itself, the same would apply to almost any electronic device that provides a separate "power on" or "reset" signal.

Possible cases are the following:

- Large capacitors in your power supply which will lead to slow leading and falling edges (issue does not apply with modern stabilized switching regulator power adaptors) and
- Slow analogue signals used to assert TO_IN

If you are in doubt, please:

- Use the mains power adapter that is provided by your distributor and is known to work properly with your modem.
- Make sure that your signal and system design is according to the above.

5.2 Configuration of the bit rate on the serial interface

The module used in the terminal does not support auto-bauding.

The default data rate is 115200 baud with 8 data bits, 1 stop bit, and no parity.

Other rates are programmable.

5.3 Power off the modem

Warning



Powering OFF the module should be done gracefully allowing the module to complete all ongoing and pending tasks while properly handling all memory buffers.

Don't interrupt this process by disconnecting the power source too early. This avoids device damage and consequently voids the warranty.

It normally takes more than 15 seconds to de-attach from the network and close the internal filesystem properly.

There are three ways to switch off (power down) the modem as described below:

1. Shut down AT-command, most preferred way:

`AT#SHDN`

The maximum time to shut down the device with this command is 25 seconds.

2. Fast shutdown AT-command:

The fast shutdown feature permits to reduce the current consumption and the time to power off to minimum values.

Force immediate fast shutdown:

`AT#FASTSHDN`

3. In the event of an unexpected power supply loss, the device can be powered down without the risk of filesystem data corruption by implementing the fast power down feature. If the voltage on VCC drops below 5V, the fast shutdown feature will be automatically triggered.

IMPORTANT: The `AT#FASTSHDN` command must be issued before any power loss occurs. Enable the fast shutdown feature on GPIO 5 with the following command:
`AT#FASTSHDN=1,5`

To check if fast shutdown is correctly configured use the command:

`AT#FASTSHDN?`

The answer should be:

`#FASTSHDN: 1,5`

OK

Warning

The command AT&F or AT&F0 (Set to Factory-Defined Configuration) will **disable** the fast shutdown functionality.

To enable it again, issue the command:

AT#FASTSHDN=1, 5



IMPORTANT: Failing to re-enable the fast shutdown functionality after it has been disabled could lead to hardware failure if you use fast shutdown.

5.4 Using low power mode of the modem

5.4.1 ENABLING THE LOW POWER MODE

- Wait until the WWAN module is logged onto the network
- Send the AT command "AT#GPIO=1,0,0" for disabling the status LED
- There are different low power modes available, for the details please consult the AT Commands Reference Guide and have a look at "AT+CFUN - Set Phone Functionality".

5.5 Operating states / green LED

The modem has a green power up LED referred as STAT_LED connected to GPIO 01. Which is used to indicate various operating states. These states are described in following table.

Default setting:

- Set alternate GPIO function: AT#GPIO=1,0,2
- Set alternate timings: AT#SLED=4
- Safe configuration: AT#SLEDSAV

AT#SLED=4 Operating state	green LED state
Device off	Permanently off
Net search / not registered	Fast blinking (0.5s ON and 0.5s OFF)
Registered full service	Slow blinking (blinking 300ms ON and 2.7s OFF)
Low power mode activated	Permanently off

Table 7: Operating states of the green LED

5.6 Status LEDs (one yellow, one red)

The yellow status LED referred as DEBUG_LED1 is controlled by GPIO 03 and the red is called DEBUG_LED2 and controlled via GPIO 02. They can be controlled via AT commands. The default status of these two LEDs is off. The following commands can be used to initialize and to configure the GPIOs to control the two LEDs:

Switching on red LED	AT#GPIO=2,1,1
Switching off red LED	AT#GPIO=2,0,1
Switching on yellow LED	AT#GPIO=3,1,1
Switching off yellow LED	AT#GPIO=3,0,1

These LEDs can be controlled e.g., by an external microcontroller via AT commands issued to the terminal via the RS232 interface. They can be used to signal any useful status of the external application such as:

- error indication
- status of communication (LTE, GPRS, SMS etc.)
- status of network (to simulate network LED)
- quality of service

5.7 Current consumption measurements

The following table shows the typical power consumption of the terminal in different modes.

Status	[mA]@7V	[mA]@12V	[mA]@24V	[mA]@32V
off (DTR low, no TO-IN)	0.1	0.25	0.61	0.85
Low power mode (AT+CFUN=5, DTR low, no USB)	1.4	1.4	1.5	1.7
Idle Mode (DTR high, CREG=1)	25	16	12	10
Technology, Band, Transmit Power				
2G, GSM1800, 1 Tx, 30dBm	130	71	43	34
2G, GSM900, 1 Tx, 33dBm	228	106	59	46
4G, B20, +23dBm	336	184	108	88
4G, B1, +23dBm	395	211	123	99

Table 8: Power consumption in standby, idle, and low power mode and active data call

5.8 Additional configuration

5.8.1 CONFIGURING MOBILE NETWORK TECHNOLOGIES

The terminal is configured by default with 4G activated and 2G as fallback. The AT command AT+WS46 can be used to modify the usage of mobile network technologies. Please refer to the Telit AT command guide for details.

5.8.3 CONFIGURING SPECIFIC FREQUENCY BANDS

In case you are using an antenna, which does not cover all frequencies specified in Section 4.2, you may configure a specific frequency band to be used with the AT command AT#BND.

6 Installation of the modem

This chapter gives you advice and helpful hints on how to integrate the LT910-EUbis terminal into your application from a hardware perspective. Please read the information given in Section 2 “Product Description” and then read the information in this section before starting your integration work.

6.1 Where to install the modem

There are several conditions which need to be taken into consideration when designing your application as they might affect the modem and its function. They are:

6.1.1 ENVIRONMENTAL CONDITIONS

The modem must be installed so that the environmental conditions stated in Section 2.4 “Product Features and Technical Data”, such as temperature, humidity and vibration are satisfied. Additionally, the electrical specifications in Section 2.4 “Product Features and Technical Data” must not be exceeded.

6.1.2 WWAN SIGNAL STRENGTH

The modem must be placed to ensure sufficient WWAN coverage. To improve signal strength, the antenna can be moved to a different position. Signal strength depends on how close the modem is to a radio base station. You must ensure that the location at which you intend to use

the modem is within the network coverage area. Degradation in signal strength can be the result of a disturbance from another source, for example an electronic device in the immediate vicinity. To verify the current signal strength, issue the command AT+CSQ.



Before installing the modem, use an ordinary mobile telephone, with the modems SIM card, to check a possible location for it. In determining the location for the modem and antenna, you should consider signal strength as well as cable length.

6.1.3 CONNECTION OF COMPONENTS TO THE LT910-EUBIS TERMINAL

The integrator is responsible for the final integrated system. Incorrectly designed or installed external components may cause radiation limits to be exceeded. For instance, improperly made connections or improperly installed antennas can disturb the network and lead to malfunctions in the modem or equipment.

6.1.4 NETWORK AND SUBSCRIPTION

Before your application is used, you must ensure that your chosen network provides the necessary telecommunication services. Contact your service provider to obtain the necessary information.

- If you intend to use SMS in the application, ensure this is included in your subscription.
- Consider the choice of the supplementary services.

6.2 How to install the modem

6.2.1 POWER SUPPLY

- Use a high-quality power supply cable with low resistance. That ensures that the voltages at the connector pins are within the allowed range, even during the maximum peak current.
- When the unit is powered from a battery or a high current supply, connect a fast 1.25 A fuse in line with the positive supply. This protects the power cabling and modem.

6.2.2 SECURING THE MODEM

Before securing the modem consider the amount of additional space required for the mating connectors and cables that will be used in the application.

- Make sure that the installation space provides sufficient air circulation, as the terminal may become warm if the module transmits regularly.
- Where access is restricted, it may be easier to connect all the cables to the modem prior to securing it in the application.

- Securely attach the LT910-EUbis terminal to the host application using two 3 mm diameter pan head screws.

6.3 Antenna

6.3.1 GENERAL

The antenna is the most important component in your system to maintain the radio link between the network and the modem. Since the antenna transmits and receives electromagnetic energy, its efficient function will depend on:

- the type of antenna (for example, omni-directional)
- the placement of the antenna
- communication disturbances in the vicinity of the antenna

The following sections address issues concerning antenna type, antenna placement, antenna cable, and possible communication disturbances. In any event, you should contact your antenna manufacturer for additional information concerning antenna type, cables, connectors, antenna placement, and the surrounding area. You should also determine whether the antenna needs to be grounded or not. Your antenna manufacturer might be able to design a special antenna suitable for the application.

6.3.2 ANTENNA TYPE

Make sure that the selected antenna meets the requirements specified in Section 4.2 ("Antenna Requirements").

6.3.3 ANTENNA PLACEMENT

The antenna should be placed away from electronic devices or other antennas. The recommended minimum distance between adjacent antennas, operating in a similar radio frequency band, is at least 50cm. If signal strength is weak, it is useful to face a directional antenna at the closest radio base station. This can increase the strength of the signal received by the modem. The modem's peak output power can reach 2W. RF field strength varies with antenna type and distance. At 10cm from the antenna the field strength may be up to 70V/m and at 1m it will have reduced to 7V/m. In general, CE-marked products for residential and commercial areas, and light industry can withstand a minimum of 3V/m.

6.3.4 THE ANTENNA CABLE

Use 50Ω impedance low loss cable and high quality 50Ω impedance connectors (frequency range up to 3GHz) to avoid RF losses. Ensure that the antenna cable is as short as possible. The voltage standing wave ratio (VSWR) may depend on the effectiveness of the antenna, cable and connectors. In addition, if you use an adapter between the antenna cable and the antenna connector, it is crucial that the antenna cable is a high quality, low loss cable. Minimize the use of extension cables, connectors and adapters. Each additional cable, connector or adapter causes a loss of signal power.

6.3.5 POSSIBLE COMMUNICATIONS DISTURBANCES

Possible communication disturbances include the following:

- **Noise** can be caused by electronic devices and radio transmitters.
- **Pathloss** occurs as the strength of the received signal steadily decreases in proportion to the distance from the transmitter.
- **Shadowing** is a form of environmental attenuation of radio signals caused by hills, buildings, trees or even vehicles. This can be a particular problem inside buildings, especially if the walls are thick and reinforced.
- **Multi path fading** is a sudden decrease or increase in the signal strength. This is the result of interference caused when direct and reflected signals reach the antenna simultaneously. Surfaces such as buildings, streets, vehicles, etc., can reflect signals.
- **Handover** occurs as you move from one cell to another in the WWAN network. Your mobile application call is transferred from one cell to the next. handover can briefly interfere with communication and may cause a delay, or at worst, a disruption.